

Bin Activators



+44(0) 1944 710421



info@severfield.com



www.severfield.com

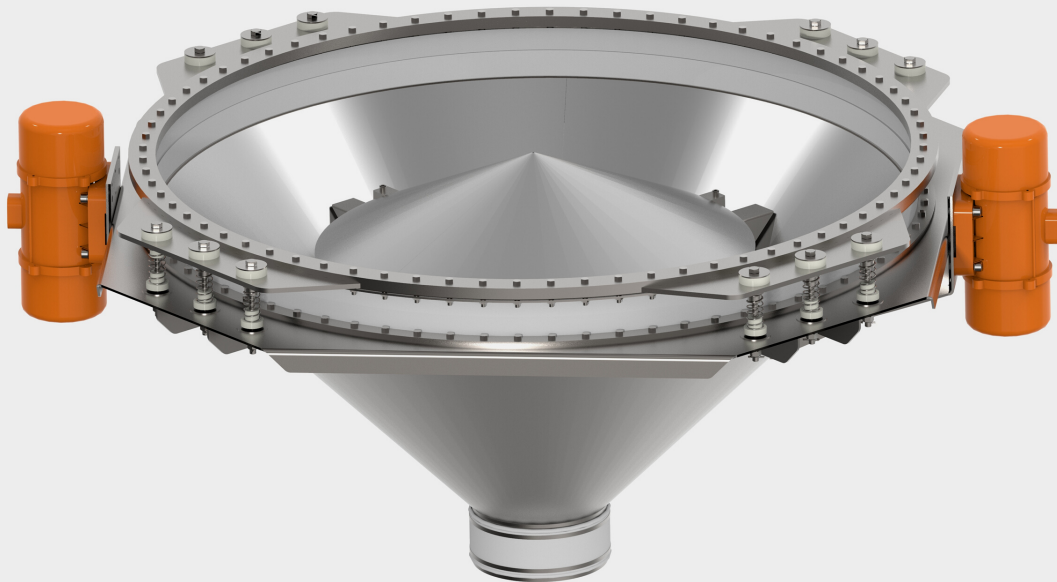

Bin Activators are commonly used to aid discharge of products where vessel geometry is compromised. Using vibration and applying this directly into the bulk solid material they aid flow and discharge of granular and powdered products from silos and hoppers.

Severfield Bin Activators are installed at a predetermined outlet diameter to suit material, vessel geometry and application. Consisting of a conical bottom and internal conical baffle the Bin Activator is supported beneath the silo or hopper to enable effective discharge.

The internal conical baffle plate is positioned above the opening of the activated section of the device working to both support the material static load above the outlet and transmit vibration directly into the product.

One or two vibrators are mounted externally which when powered cause material to move steadily within the silo or hopper where material passes around the annular space between the baffle and the body of the bin discharger.

Once passing the device material is in a state of flow and is discharged into the outlet section of the Bin Activator which can be coupled to your downstream process. Bin Activators can provide a limited degree of discharge rate control but are not volumetric devices. Where greater accuracy and complete control is required Rotoflo should be considered.

- Convenient and economical solution.
- Can be easily retrofitted to silos and hoppers.
- Low headroom design with central discharge.
- Options in carbon steel, 304 / 316L stainless steel.
- Sizes from Ø 900mm (3ft) ~ 2,100mm (7 ft)
- Powerful, compact design
- Multiple gasket and sleeve options including food grade versions.
- Baffles to suit all applications.
- Relatively low power requirements.

Bin Activators



+44(0) 1944 710421



info@severfield.com



www.severfield.com

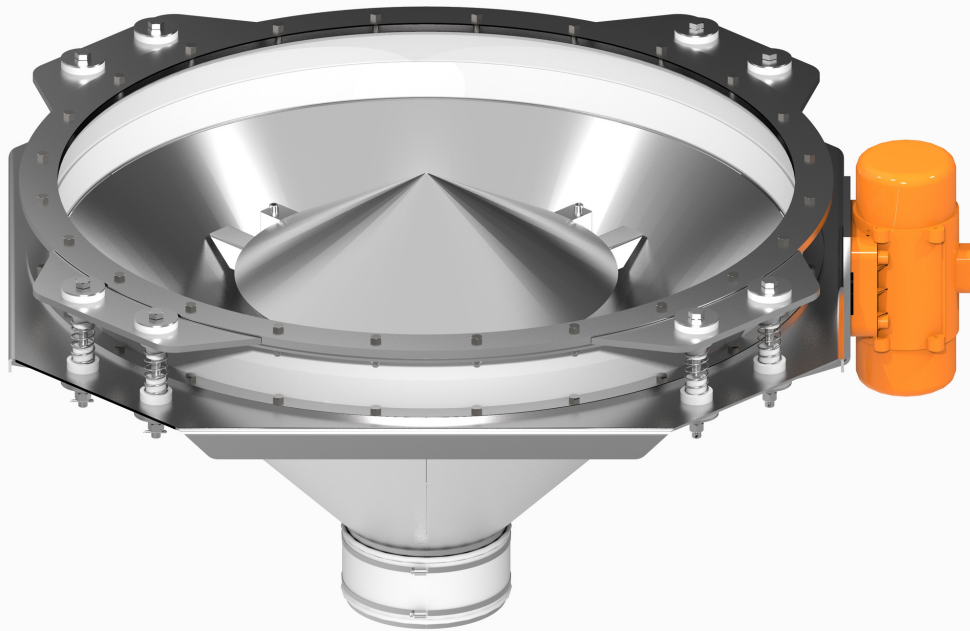

Model Availability

Material of Construction	Model
Epoxy Coated Mild Steel	Bin Activator, Model BA900
	Bin Activator, Model BA1250
	Bin Activator, Model BA1500
	Bin Activator, Model BA1800
	Bin Activator, Model BA2100
AISI304 Stainless Steel	Bin Activator, Model BA900
	Bin Activator, Model BA1250
	Bin Activator, Model BA1500
	Bin Activator, Model BA1800
	Bin Activator, Model BA2100
AISI316L Stainless Steel	Bin Activator, Model BA900
	Bin Activator, Model BA1250
	Bin Activator, Model BA1500
	Bin Activator, Model BA1800
	Bin Activator, Model BA2100